

VL-9998-24 SUPERVISED IDF

INTRODUCTION

These instructions contain the specifications and guidelines necessary to install, operate, and maintain the VL-9998-24 Rack or Wall Mount Supervised IDF.

The VL-9998-24 provides audio, 24VDC and wire monitoring for up to 12 supervised self amplified speaker runs in a single zone configuration or may be configured for 2 paging zones with 6 speaker runs in each zone. Up to (6) 1 Watt interior speakers may be connected to each output or (1) 5 Watt Paging horn. **Note: Consult Valcom Services L.L.C. for other configurations.**

The unit provides both audible and visual indication of wire faults.

SPECIFICATIONS

Features

- Red Alarm Led
- Power Indicators (Green)
- Pushbutton Switch (Fault Silence)
- Individual Speaker Line Status Indicators (Red Led's)
- Bypass Selection for Each Output
- Buzzer for Audible Alarm
- 2 Audio Input 110 Terminal Connections
- Fault Contact Closure
- Speaker Cable Connection: 8 Position 110 Terminals
- Alarm Output Connection

Power Requirements

Operating Voltage: 24 – 26VDC
Current: 100mA

System Supervision

Speaker Audio Output – DC loop terminated with a V-9999 EOL unit.

All system faults are indicated by both an audible and visual alarm. The audible alarm may be silenced however the visual indicator will continue to illuminate until the fault is repaired.

Fault “auto reset” occurs after the circuit is repaired.

If unit is configured for 2 page zones, it appears as a single fault to the monitoring system.

User Controls

- Push button silence switch – Silences local audible alarm only
- Zone supervision by-pass jumper - (Removes supervision from unused outputs)
- Audio Link Switch – (Allows the unit to provide supervision for 2 page zones – 6 speaker circuits each)

Indicators

- Power “ON” Green Led
- Red Alarm Led for each output
- Visual system main fault
- Audible system fault with silence button

Inputs

One audio input for each zone of 6 speaker line connections

Outputs

- 12 speaker line outputs divided into 2 zones six speaker lines each.
- External alarm output (contact closure)

System Operation

The supervision module continuously monitors the speaker runs for both opens or shorts and provides both audible and visual indication of wire faults. In the event of a speaker run wire fault, the VL-9998 provides a red LED indication identifying which speaker run has the fault and sounds a local buzzer on the panel for an audible alarm. A (N.O.) contact closure is provided allowing remote fault indication in the event of a wire fault. A pushbutton on the front of the panel provides audible alarm silencing but does not affect the visual alarm or contact notifications. Once the fault is removed, all alarm notifications are automatically reset.

Troubleshooting

Fault Condition – Disconnect suspect speaker line from system and move supervision jumper to by-pass position. (Figure 1) If the fault clears check speaker ling for opens or shorts using a Volt-Ohm Meter. After the speaker line fault has been corrected reconnect to unit and move the by-pass jumper to supervise position. (Figure 1) If the fault does not clear, call for assistance.

VOM and a test set and call from the job site. Call (540) 427-2400 or visit our website at <http://www.valcomservicesllc.com>

Valcom Services equipment is not field repairable. Valcom Services maintains service facilities in Roanoke, VA. Should repairs be necessary, attach a tag to the unit clearly stating company name, address, phone number, contact person, and the nature of the problem. Send the unit to:

TECHNICAL ASSISTANCE

When trouble is reported, verify the unit is turned on and there are no broken connections leading to the unit.

Valcom Services L.L.C.
Repair and Return Dept.
5614 Hollins Road
Roanoke, VA 24019-5056

Assistance in troubleshooting is available from the factory. When calling, you should have a

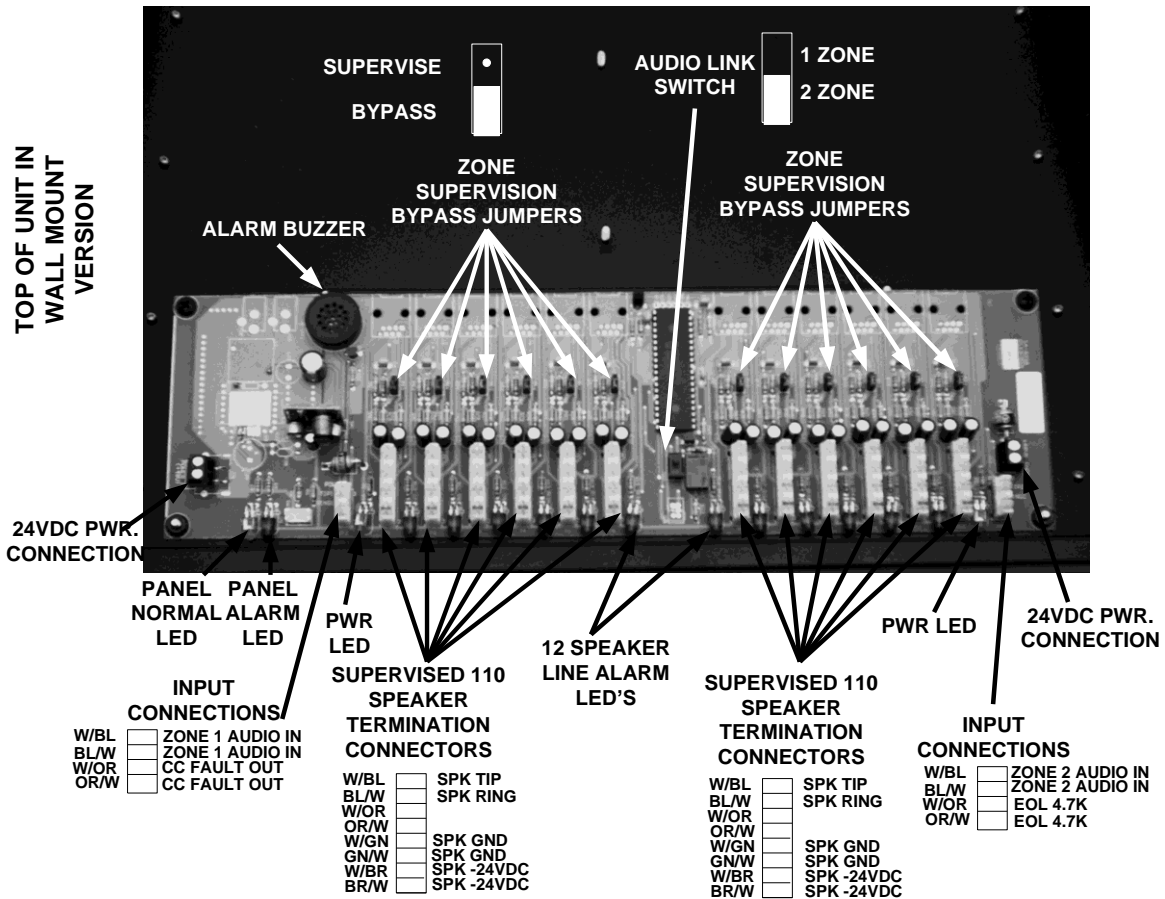

FIGURE 1: VL-9998 UNIT LAYOUT

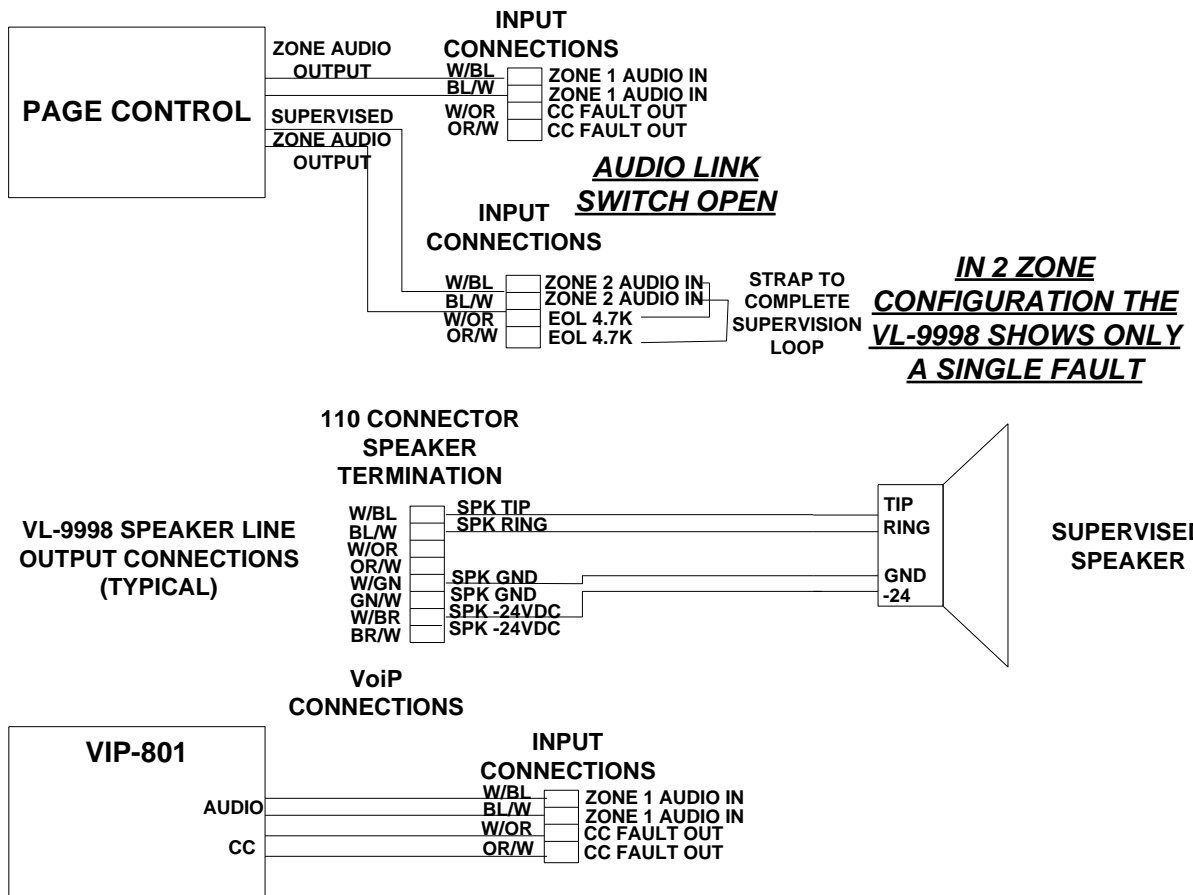

FIGURE 2: TYPICAL CONNECTIONS

VALCOM SERVICES L.L.C. LIMITED WARRANTY

Valcom Services L.L.C. warrants its products only to the original purchaser, for its own use, to be free from defects in materials and workmanship under conditions of normal use and service for a period of one year from the date of shipment. This Limited Warranty obligation shall be limited to the replacement, repair or refund of any such defective device within the warranty period, provided that:

1. inspection by Valcom Services L.L.C. indicates the validity of the claim;
2. the defect is not the result of damage, misuse or negligence after the original shipment;
3. the product has not been altered in any way or repaired by others and that factory sealed units are unopened (a service charge plus parts and labor will be applied to units defaced or physically damaged);
4. freight charges for the return of products to Valcom Services L.L.C. are prepaid;
5. all units 'out of warranty' are subject to a service charge. The service charge will cover minor repairs (major repairs will be subject to additional charges for parts and labor).

This Limited Warranty is in lieu of and excludes all other warranties, expressed or implied and in no event shall Valcom Services L.L.C. be liable for any anticipated profits, consequential damages, loss of time or other losses incurred by the buyer in connection with the purchase, operation, maintenance, installation, removal or use of the product. The maximum liability of Valcom Services L.L.C. under this warranty is limited to the purchase price of the specific Product covered by the warranty.

Disclaimer. Except for the Limited Warranty provided herein, the product is provided "as-is" without any warranty of any kind whatsoever including, without limitation, any **WARRANTY OF MERCHANTABILITY, FITNESS FOR A PARTICULAR PURPOSE OR NON-INFRINGEMENT.**

This warranty specifically excludes damage incurred in shipment. In the event a product is received in damaged condition, the carrier should be notified immediately. Claims for such damage should be filed with the carrier involved in accordance with the F.O.B. point.

Headquarters:
 Valcom Services L.L.C.
 5614 Hollins Road Roanoke, VA 24019-5056
 Phone: (540) 563-2000 FAX: (540) 362-9800